

# Stacked tailings without pressure filtration: pilot-scale application of ATA rapid dewatering technology

Adam J Fischmann <sup>a, \*</sup>, Janna van der Linde <sup>b</sup>, Carien Spagnuolo <sup>b</sup>

<sup>a</sup> Clean TeQ Water, Australia

<sup>b</sup> Clean TeQ Water, South Africa

## Abstract

*To achieve desaturation and the required moisture level tailings, filtering is required. In many cases, the capital cost of pressure filtration is prohibitive while lower cost vacuum filtration is unable to meet the required solids target (typically greater than 80% w/w solids). By anchoring fine particles to coarse particles using the dual polymer ATA<sup>®</sup> conditioning system, a granular and homogenous particle network structure is formed, resulting in improved dewatering efficiency. This enables acceptable solids concentrations using vacuum filtration in combination with a vibratory roller.*

*This paper presents the results from a pilot-scale demonstration of ATA conditioning on tailings from an Australian Pb-Zn operation, conducted at a throughput of 0.5 t/h. A 2 m<sup>3</sup> sample of tailings was split using a hydrocyclone and then treated in the ATA pilot unit.*

*The dewatering performance of the ATA-treated tailings was assessed using a vacuum filtration pilot unit, enabling variation of the cake thickness, drying time and vibration conditions. A friable cake was produced at a filtration rate of 0.84 t/h/m<sup>2</sup>, containing 87.5% w/w solids. Geotechnical assessments showed that ATA-treated tailings filtered by vacuum filtration had a lower optimum moisture content and higher maximum dry density compared to untreated tailings. No significant difference in triaxial shear strength was observed between the treated and untreated material.*

*This study demonstrates that ATA conditioning facilitates the production of low moisture, dry-stackable material using vacuum filtration, while maintaining comparable geotechnical properties to the benchmarked untreated tailings. The combination of an efficient hydrocyclone fines/coarse split with ATA conditioning and vacuum filtration unlocks a lower cost pathway to filtered tailings.*

**Keywords:** *tailings filtration, stacking, polymer conditioning, vacuum filtration, case study*

## 1 Introduction and objective

Tailings dewatering continues to be a challenge for the mining industry. The drivers include managing water balance (both positive and negative), tailings volume reduction, and mine closure and safety considerations. Often the limiting factor for more intensive dewatering is the capital and operating costs of plate and frame pressure filtration. A past paper detailed the application of the ATA process to improve filtration performance of iron ore and copper tailings at laboratory-scale (Fischmann et al. 2025). Here we report a pilot-scale study showing that the combination of the ATA process with vibration-assisted vacuum filtration was able to meet the dewatering requirements for an Australian Pb-Zn operation, with significant capital cost savings compared to pressure filtration. The moisture target as specified by the client was 12.7% w/w (87.3% w/w solids), based on geotechnical studies of untreated tailings. All solids' concentrations are given as mass of solids over total mass of solids and water, and all moisture concentrations as mass of water over total mass of solids and water.

---

\* Corresponding author.

ATA offers a novel approach by separately treating coarse and fine fractions (produced using conventional technology such as hydrocyclones, or already existing in an operation) with pairs of complementary polymeric reagents (see, for example, Berg et al. [2013]). The fine stream is treated with an activator while the coarse stream is treated with a tether, creating anchor particles, hence A-T-A (Figure 1).

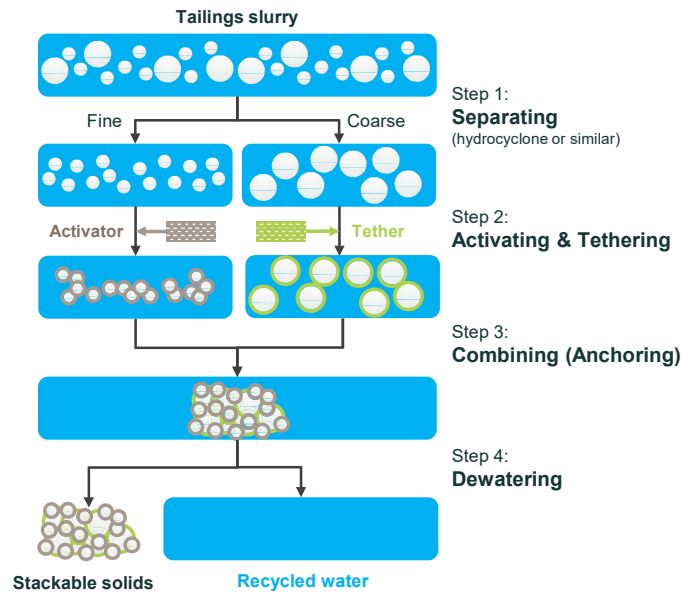

**Figure 1 Schematic of the ATA process**

When the activated fines are combined with the tethered coarse material (anchors), the fine particles are attracted to the anchors, form large agglomerates and rapidly settle. The agglomerate network has a rigid, open structure that rapidly dewateres through a porous medium such as a screen, geotextile or filter. Due to the attractive forces between the fine and coarse particles, exceptionally low turbidity water is released, and fines capture (and recapture) can be dramatically improved compared to conventional flocculation with a single reagent. The reagents are strongly attracted to the solids and have similar environmental profiles to flocculants used in mining and water treatment applications. Once desaturated, the strength of the dewatered solid network is dominated by particle–particle forces rather than the polymers, and therefore long-term stability is not expected to be affected by polymer degradation.

ATA has been demonstrated at laboratory-scale on tailings from a wide variety of commodities, including gold, copper, diamond, phosphate, iron ore and mineral sands, and piloted on diamond, gold and phosphate tailings.

## 2 Materials and methods

### 2.1 Polymeric reagents

The ATA activator and tether reagents are proprietary polymers. The polymers were dissolved at 0.2% w/w in deionised water. Dosages were optimised based on visual observations of agglomerate formation and settling behaviour of jar tests with coarse and fine fractions, and the recombined tailings.

### 2.2 Tailings characterisation

Tailings were received from site in bulk containers as a 37.9% w/w slurry, with the particle size distribution as shown in Figure 2. The water associated with the tailings had a dissolved solid content of 0.7% w/w and a pH of 6.4. After determining the cyclone conditions to produce the desired split, the tailings were processed through the cyclone in batches. Figure 2 shows the particle size distribution (PSD) for the as-received tailings, cyclone overflow, cyclone underflow, and the recombined tailings exiting the ATA rig. The split produced well-separated

coarse and fine fractions. Table 1 lists the classification testing results for the untreated and ATA-treated tailings. For geotechnical testing, treated tailings were collected as a slurry, decanted to remove the supernatant, then filtered at 400 kPa in an air-driven pressure filter (Alsto). For vibration-assisted vacuum filtration testing, treated tailings were collected as a slurry and decanted to remove the supernatant. Details of the geotechnical testing, cyclone testing, ATA process and filtration testing are provided in the following sections.

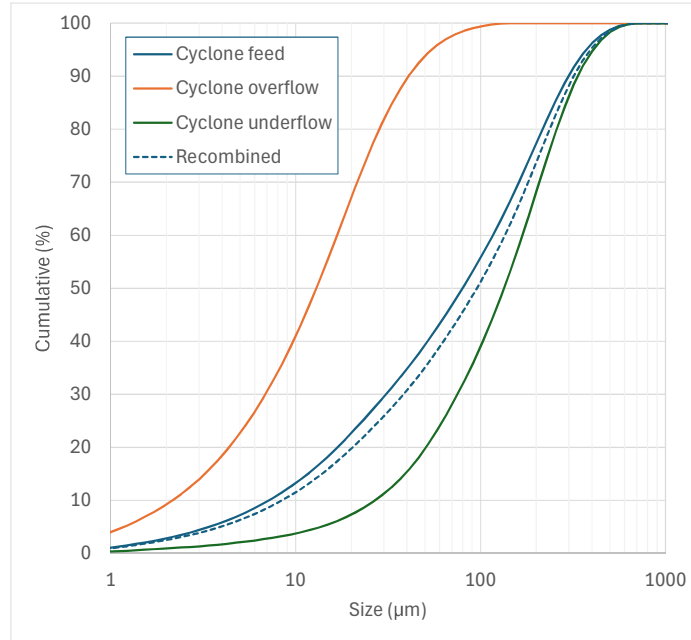

**Figure 2 Particle size distribution of tailings**

**Table 1 Classification testing results for untreated and ATA-treated tailings**

Sample	Salt corrected particle density, $\rho_s$ (t/m <sup>3</sup> )	Clay sized	Gradation (%)			Atterberg limits (%)		
			Silt	Sand	Gravel	LL	PL	PI
Treated	2.92	6	56	38	0	22	NP	NP
Untreated	2.95	6	49	45	0	25	17	8

Notes: clay sized < 2 µm, silt sized < 75 µm and > 2 µm, sand sized > 75 µm and < 236 µm, gravel sized > 236 µm and < 60 mm, NP = not present, LL = liquid limit, PL = plastic limit, PI = plastic index

### 2.3 Cyclone test work procedures

The cyclone test work was conducted by Weir using a Cavex® 150CVX cyclone (Figure 3) with a 150 mm diameter, a 6° cone angle and a 41 mm inlet. The effects of varying the vortex finder, spigot diameters, and the cyclone pressure/feed flow rate on the cyclone split were assessed by measuring the solids concentration and distribution, and PSD of cyclone underflow (CUF) and cyclone overflow (COF).

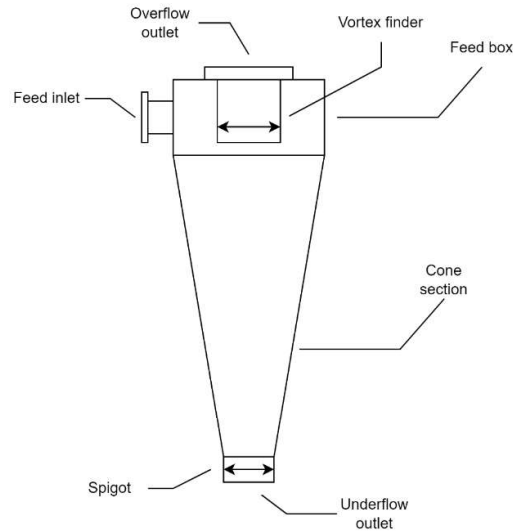
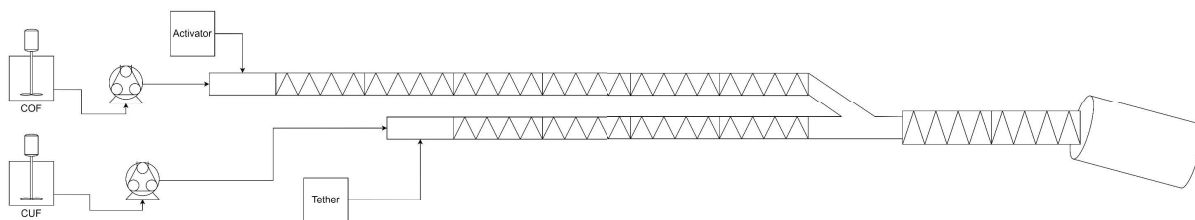

**Figure 3 Schematic of a hydrocyclone**

A portion of the tailing's slurry was contained in an agitated feed tank (2.25 m<sup>3</sup> capacity) and pumped into the cyclone using a centrifugal pump. During operation, the overflow and underflow streams passed through flow diverters for the streams to be either collected or recycled to the feed tank. The collection tanks sat on load cells, and sub-samples were obtained for characterisation. A Coriolis densitometer was used to measure the feed slurry density, temperature, and mass flow rate. The feed volumetric flow rate was measured using a magnetic flow meter. The cyclone feed pressure and pump output pressure were measured with pressure transducers. For each set of conditions, the feed tank was agitated until a constant slurry density was measured by the Coriolis densitometer at suitably high flow rates. The solids concentration was confirmed by oven drying of samples.

## 2.4 ATA piloting

A custom modular static mixer rig was constructed to produce ATA-treated tailings in a continuous process (see Figures 4 and 5). To feed the rig, the COF was stored in a 5 m<sup>3</sup> agitated tank and pumped using a calibrated peristaltic pump into a pipe connected to the activating set of static mixers (32 mm internal diameter [ID]). The activator solution was pumped using a peristaltic pump into the pipe through a valve just ahead of the static mixers. The CUF was stored in an agitated 1 m<sup>3</sup> bulk container and pumped using another calibrated peristaltic pump into the Tethering leg of the static mixer rig (32 mm ID), and the tether solution was pumped using another peristaltic pump, similarly to the activator. The COF and CUF were pumped at relative flow rates, such that when combined the PSD of the tailings was equivalent to the as-received tailings. The flow rates of the reagent pumps were calibrated while pumping reagent into the flowing slurries, to account for any effects of back pressure on the reagent flow rate. The static mixers were made of transparent PVC to facilitate visual observation of agglomeration and structure development.



**Figure 4 Schematic of static mixer rig**



**Figure 5** Static mixer rig set up

The outlets of the activating and tethering static mixer legs were combined in a Y-connector and flowed into a larger diameter set of static mixers (40 mm ID) to mix the treated streams together and produce the ATA-treated tailings. A large diameter PVC pipe was positioned at the outlet of the final static mixer to slow down the linear velocity – to ensure minimisation of shear during sample collection. Samples of the treated tailings were collected in 1 L measuring cylinders to assess settling; in 200 mL sample jars for filtration testing; and in 20 L buckets for preparation of samples for geotechnical testing. The total mass flow exiting the rig was periodically checked by collecting a bucket of treated slurry in a given period of time and measuring the mass.

## 2.5 Vacuum filtration procedures

The vacuum filtration test work was carried out by Jord International, using a custom vacuum filtration setup, on ATA-treated tailings. Tests were conducted at 50 kPa vacuum pressure, using varying amounts of tailings to obtain a range of cake thicknesses. For tests utilising vibration-enhanced filtration, vibration was applied to the top surface of the cake, after cake formation, with a pneumatically-driven piston.

## 2.6 Geotechnical methods

The geotechnical methods used for characterisation and testing of the tailings are summarised in Table 2. All geotechnical testing was carried out by WSP in Perth.

**Table 2 Geotechnical testing methods**

Test purpose	Test description	Standard/procedure reference
Classification testing	Absolute particle density	Australian standard, AS 1289.3.5.1 (Standards Australia 2025)
	Salt corrected particle density	WSP procedure, WSPMW 1.1.5 (Fanni et al. 2019; Mmbando et al. 2024a; Mmbando et al. 2024b)
	Atterberg limits (liquid limit by cone penetrometer)	Australian standards, AS 1289.3.9.1, (Standards Australia 2015), AS 1289.3.2.1 (Standards Australia 2009a), AS 1289.3.3.1 (Standards Australia 2009b) and AS1289.3.4.1 (Standards Australia 2008)
	Standard maximum dry density (SMDD)	Australian standard, AS 1289.5.1.1-2017 (Standards Australia 2017a)
Critical state line testing	Modified maximum dry density (MMDD)	Australian standard, AS 1289.5.2.1-2017 (Standards Australia 2017b)
	'Loose' specimen preparation for triaxial testing by moist tamping	WSP procedure, WSPMW 3.1.1 (Jefferies and Been 2016)
	Strain controlled triaxial testing	WSP procedure, WSPMW 3.2.1 (Jefferies and Been 2016; Ladd 1978; ASTM International 2020a; ASTM International 2020b)
Strength testing	Compacted specimen preparation for direct simple shear testing	WSP procedure, WSPMW 4.1.2 (Reid et al. 2022)
	Monotonic direct simple shear testing	American standard, ASTM D6528 (ASTM International 2017)
	Cyclic direct simple shear testing	American standard, ASTM D8296 (ASTM International 2019)

### 3 Results and discussion

#### 3.1 Cyclone testing

A number of different cyclone configurations were tested, which produced varying splits. The splits were assessed on the basis of how well the fines were separated from the coarse particles. The selected split had a low proportion of fines in the CUF (21% passing 75  $\mu\text{m}$ ), and a low proportion of coarse particles in the COF (95% passing 75  $\mu\text{m}$ ), with 82% w/w of the solids recovered in the CUF. The coarse to fines ratio was 4.6 (by mass). The COF slurry contained 12% w/w solids and the CUF slurry contained 72% w/w.

#### 3.2 ATA testing

The slurries were pumped from agitated tanks into the static mixer rig at a combined solids flow rate of 0.5 t/h, at relative flow rates such that the PSD of the tailings prior to splitting was restored. At these flow rates, residence times were approximately 10 s for both the COF and CUF in the activating and tethering static mixers, and approximately 5 s for the combined slurries in the final static mixer. Prior to switching on the ATA reagent pumps, no agglomeration or structure was visible in the slurries flowing within the static mixers, and the combined slurry exiting the rig settled poorly and segregated. After switching on the reagent pumps, agglomeration was quickly apparent in all static mixers. For both the COF and the CUF, the size of the

agglomerates clearly increased along the flow path, showing that the slurry was neither being over-mixed nor causing degradation of agglomerates. The combined treated streams immediately formed a homogeneous granular structure in the combined static mixer. The ATA-treated tailings settled rapidly with a clear supernatant and did not segregate after deposition. The ATA-treated tailings consolidated rapidly, forming a distinct pile and yielding a clear supernatant. In contrast, the untreated tailings, spread out and the supernatant was highly turbid. These features of the ATA-treated tailings are shown in Figure 6.

Under optimised conditions, the dosage of activator polymer to the COF was 300 g/t and the dosage of tether polymer to the CUF was 75 g/t. In each case, the dosages refer to active polymer relative to solids content of the slurry.

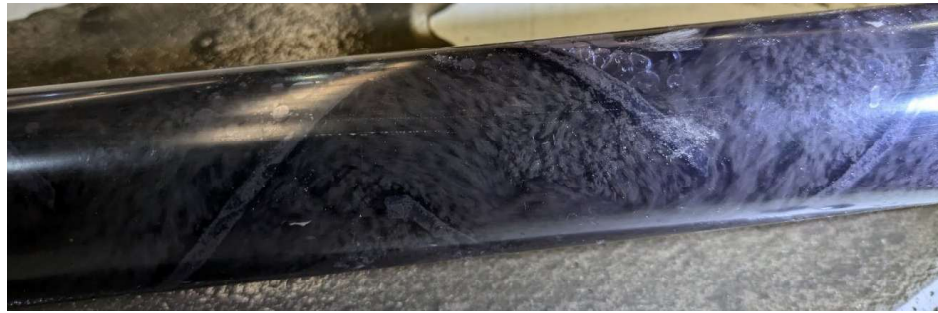

(a)



(a)

(b)

(c)

**Figure 6 (a) ATA static mixer outlet showing agglomerates in the mixer; (b) Settled tailings showing granular structure and clear supernatant; (c) Granular structure of treated solids, clear water released along the sides, and laminar flow out of the large diameter pipe; (d) Deposited ATA-treated tailings piling up and releasing clear water**

### 3.3 Vacuum filtration results

The optimal cake thickness was determined by filtering varying quantities of ATA-treated tailings. Figure 7a shows that at a cake thickness greater than 24 mm, there is an exponential increase in the form time (time required for liquid to filter to the cake surface, i.e. no free water above the cake). The optimal cake thickness is therefore 24 mm or less. The effect of cake thickness on cake moisture is shown in Figure 7b. In operations, higher cake thickness generally results in improved cake stability on the belt but higher cake moisture (for a constant drying time). Therefore, a trade-off between cake moisture and cake thickness must be made. The cake thickness best balancing these 2 factors was 20 mm, due to the small moisture penalty compared to a 16 mm cake, and the large moisture penalty compared to a 24 mm cake.

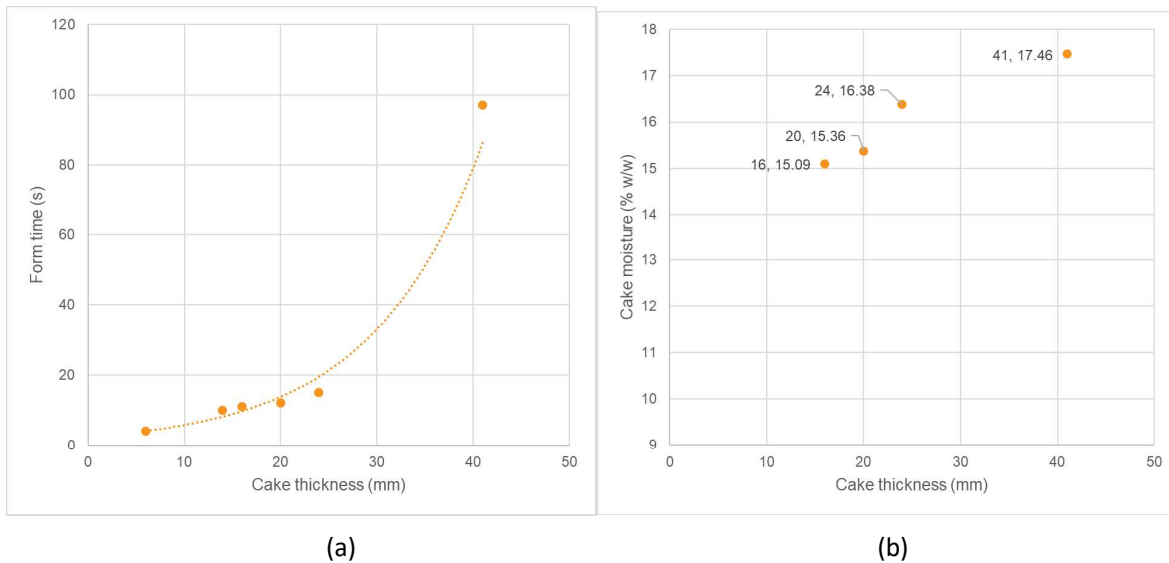

**Figure 7 (a) Effect of cake thickness on form time; (b) Effect of cake thickness on cake moisture, at constant drying time of 120 s**

Due to the high hydraulic conductivity of ATA-treated tailings, the application of vibration was expected to further reduce the moisture content of the filter cake. Jord's proprietary Viper™ technology (consisting of a vibrating roller installed on a vacuum filter belt) provided vibration and compression to induce liquefaction in the filter cake, releasing water which was then removed by the vacuum (Whatnall et al. 2021). As described in Section 2.5, Jord's custom filtration apparatus can apply vibration (with variable frequency, amplitude and duration) onto the filter cake after cake formation, to simulate the effect of the vibrating rollers. Figure 8 compares the effect of total cycle time on cake moisture, with and without vibration. The data showed that:

- consistently lower cake moisture was achieved with vibration
- vibration increased filtration rate, such that longer cycle times had a much smaller effect than without vibration.

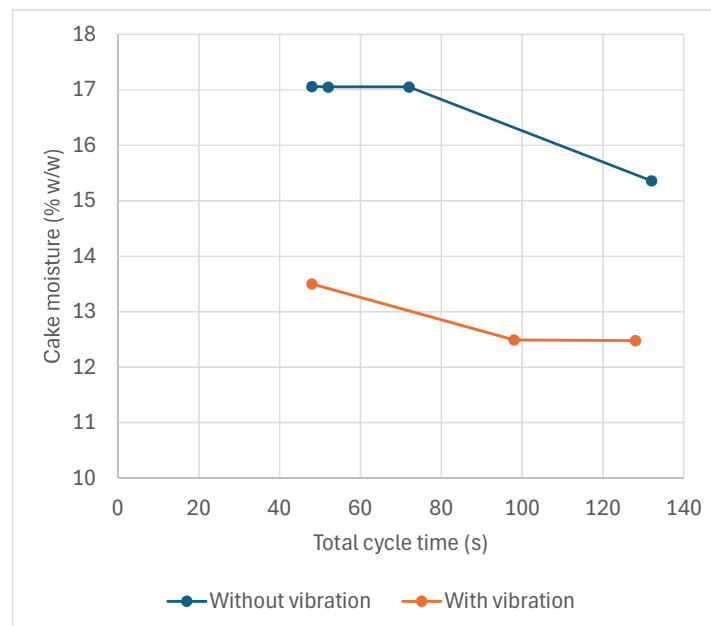

**Figure 8 Effect of vibration on cake moisture at varying total cycle times**

The filtration testing on the ATA-treated tailings showed that to produce a 20 mm cake at 12.5% w/w moisture (87.5% w/w solids), following cake formation (8 s), the application of 30 s of vibration and 90 s of drying time would be required. This combination of formation, vibration and drying times resulted in a filtration rate of 0.84 t/h/m<sup>2</sup>.

### 3.4 Geotechnical results

The vibration-assisted vacuum filtration study of the ATA-treated tailings demonstrated that the moisture target could be achieved without the need for pressure filtration. However, a key question remained regarding whether the ATA process influenced the geotechnical properties of the dewatered tailings. To address this, the client commissioned WSP to carry out a program of geotechnical studies using untreated tailings as the reference material for comparison.

Standard and modified maximum dry density tests were carried out on treated and untreated tailings. As shown in Figure 9, the ATA-treated tailings resulted in higher maximum dry densities at lower moisture content than the untreated tailings.

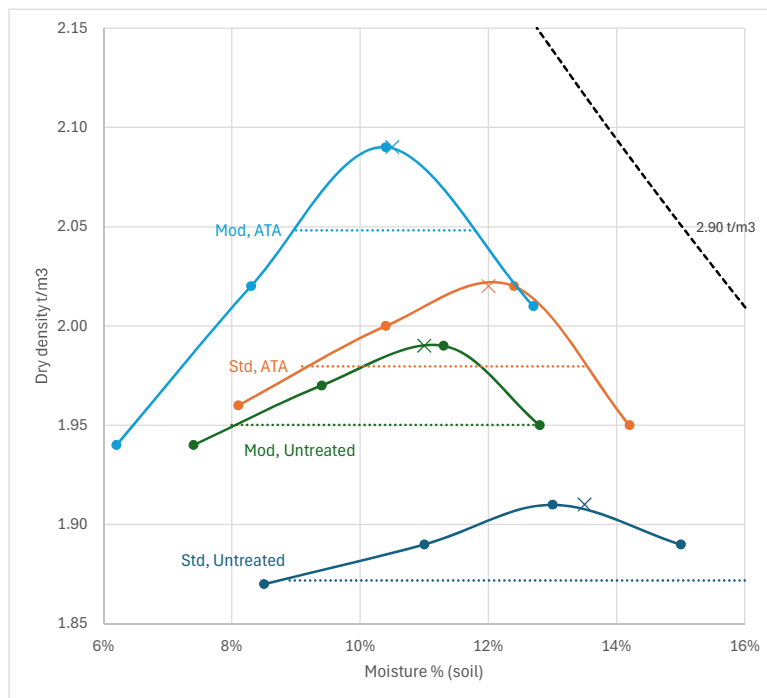

**Figure 9 Standard and modified maximum dry density test data – note moisture is expressed as soil moisture (water/solids, not water/total) (dotted lines show dry density at 98% of maximum)**

Critical state line testing (triaxial) showed that there was little difference between the untreated and ATA-treated tailings from this perspective. The critical friction angle for both untreated and ATA-treated tailings was 34°. Figure 10a shows that the inferred critical state lines of the untreated and ATA-treated tailings are similar over the stress range applicable to the site, i.e. 10 to 1000 kPa mean effective stress. The projected consolidation lines show the stress at which the ATA-treated tailings are susceptible to becoming 'loose' due to additional placement of material. Figure 10b predicts that the ATA-treated tailings, initially compacted to 95% SMDD, evolve to the boundary of dilative/contractive behaviour at a vertical effective stress of approximately 115 kPa and after initial compaction to 95% MMDD, this is predicted to occur at approximately 320 kPa.

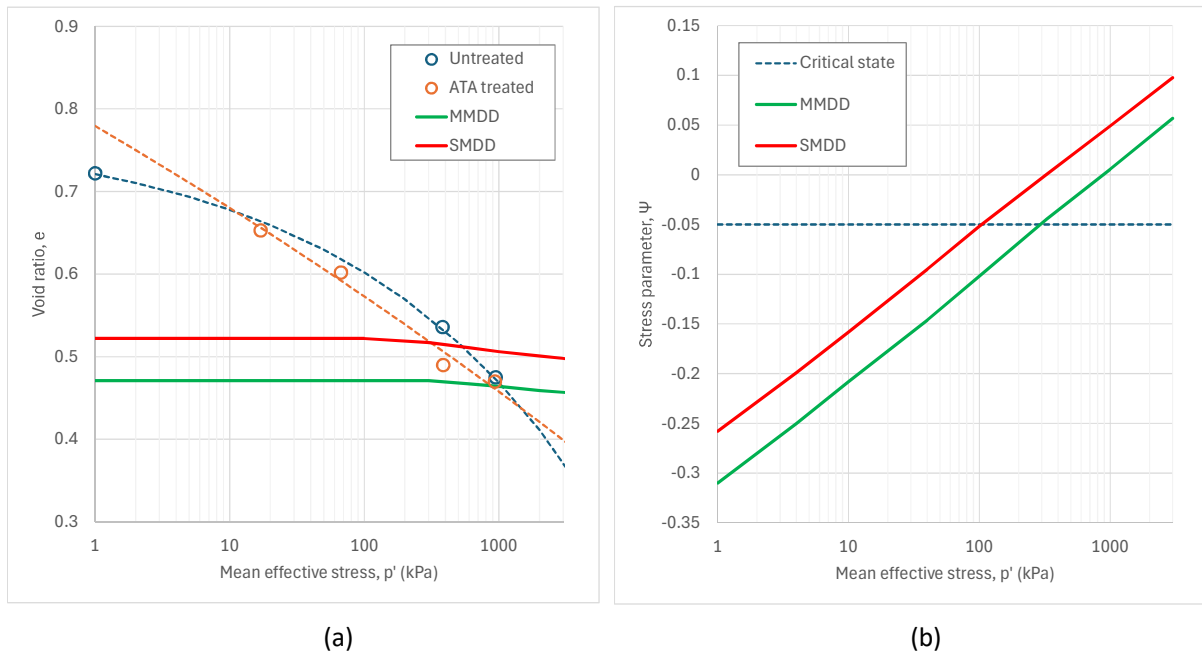

**Figure 10 (a) Inferred critical state lines for untreated and ATA-treated tailings with projected consolidation lines at 95% compaction; (b) Evolution of state parameter for compacted ATA-treated tailings**

### 3.5 Techno-economic assessment

The client has a strict moisture target of 12.7% w/w (87.3% w/w solids) to satisfy geotechnical requirements for filtered tailings, which as discussed in Section 3.4, was not affected by the ATA process. A previously completed techno-economic assessment by the client found that pressure filtration was approximately double the capital cost of vacuum filtration, but vacuum filtration was unable to meet the geotechnical moisture target. The results presented in this paper show that the combination of ATA treatment and vibration-assisted vacuum filtration successfully achieves the target moisture content, thereby enabling consideration of a lower capital cost filtration pathway that was previously not technically viable.

An indicative comparison of the capital and operating costs for the filtration options considered is presented in Table 3. The relative capital and operating cost relationships observed are consistent with earlier scoping-level assessments for the same tailings stream, in which pressure filtration exhibited approximately 1.7–1.9 times the capital cost of vacuum filtration at comparable throughput. The present results therefore reflect a change in achievable moisture performance enabled by ATA conditioning rather than a change in the underlying economic characteristics of the filtration technologies.

**Table 3 Indicative economic comparison**

Filtration option	Indicative capex (M AUD)	Annual opex (M AUD/a)	Primary opex drivers
Plate and frame pressure filtration (no ATA)	~16–17	~1.6–1.75	Power, maintenance, filter cloths
Plate and frame pressure filtration (with ATA)	~16–17	~1.6	ATA reagents, reduced cycle time, similar power demand
Horizontal vacuum belt filtration (with ATA)	~9–10	~1.3	ATA reagents, lower power demand, lower maintenance

On an indicative basis, assuming constant real operating costs over a 20-year operating period and an 8% discount rate, the corresponding net present value (NPV) of the filtration plant is approximately AUD 33–34 M for pressure filtration without conditioning, AUD 32–33 M for pressure filtration with ATA, and approximately AUD 22 M for vacuum filtration enabled by ATA conditioning. The reduction in NPV is primarily driven by the lower capital intensity of the vacuum filtration option, despite the inclusion of reagent costs in the operating expenditure.

Implementation of ATA dewatering in the flow sheet is shown schematically in Figure 11 and the projected process parameters for full-scale application is summarised in Table 4. The tailings slurry is first split with a hydrocyclone into coarse (COF) and fine (COF) fractions. The COF is dosed with the activator reagent ahead of a static mixer, and the CUF is dosed with tether ahead of a static mixer. The treated COF and CUF are then combined in a third static mixer to produce the ATA-treated tailings, which are then delivered directly to the vibration-assisted vacuum filter. Filtrate is collected and pumped back to the flotation plant as process water, and the filter cake is stacked.

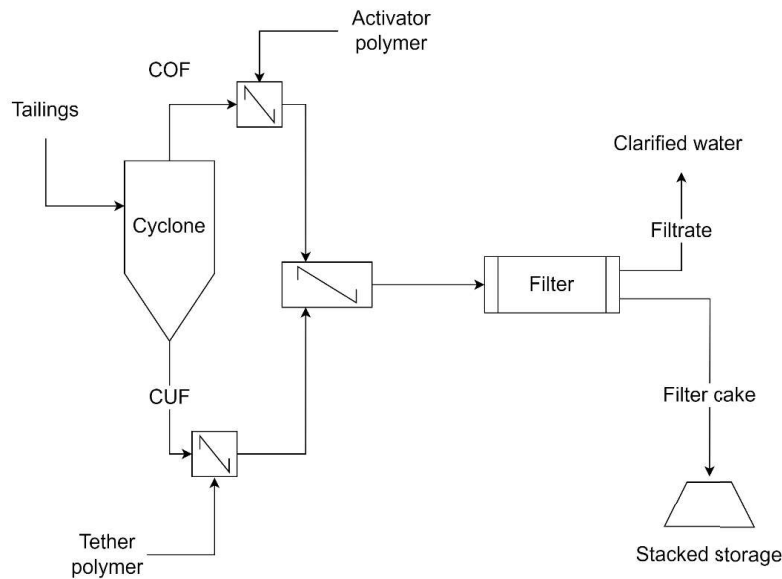

**Figure 11 Schematic flow sheet for implementing ATA dewatering**

**Table 4 Projected process parameters**

Parameter	Unit	Value	Parameter	Unit	Value
Tailings solids flow rate	t/h	100	CUF solids content	% w/w	72
Tailings volumetric flow rate	m <sup>3</sup> /h	178	Activator dosage	g/t	300
Tailings solids content	% w/w	36	Tether dosage	g/t	75
Cyclone overflow solids flow rate	t/h	20	Filtration throughput	t/m <sup>2</sup> /h	0.84
Cyclone overflow solids content	% w/w	12	Cake thickness	mm	20
Cyclone underflow (CUF) solids flow rate	t/h	80	Filter area required	m <sup>2</sup>	119

## 4 Conclusion

This case study, conducted using cycloned Australian Pb-Zn tailings, demonstrated that ATA dewatering can be effectively implemented in a continuous process at pilot-scale (0.5 t/h solids) using static mixers. The ATA process produced a readily dewatered material amenable to vacuum filtration, without affecting the geotechnical properties of the resulting filter cake. Vibration-assisted vacuum filtration of the ATA-treated

material proved highly effective at achieving a very low moisture content. The achievement of >87.5% w/w solids in the filter cake – through the combined use of ATA and vibration-assisted vacuum filtration – positions this approach as a viable alternative to pressure filtration, delivering comparable dewatering performance at substantially lower capital cost, and thereby enabling stacking of filtered tailings in a broader range of operations. From a techno-economic perspective, this shift enables a reduction in life cycle costs by allowing the adoption of lower capital cost filtration technologies, while maintaining compliance with geotechnical moisture requirements.

## Acknowledgement

The authors greatly acknowledge the assistance of personnel at the Weir Technical Centre for carrying out the cyclone testing and assisting with the ATA pilot, and to the client for allowing publication of the results.

## References

- ASTM International 2017, *Standard Test Method for Consolidated Undrained Direct Simple Shear Testing of Fine Grain Soils (ASTM D6528-17)*, ASTM International, West Conshohocken.
- ASTM International 2019, *Standard Test Method for Consolidated Undrained Cyclic Direct Simple Shear Test Under Constant Volume With Load Control or Displacement Control (ASTM D8296-19)*, West Conshohocken.
- ASTM International 2020a, *Standard Test Method for Consolidated Undrained Triaxial Compression Test for Cohesive Soils (ASTM D4767-11(2020))*, West Conshohocken.
- ASTM International 2020b, *Standard Test Method for Consolidated Drained Triaxial Compression Test for Soils (ASTM D7181-20)*, West Conshohocken.
- Berg, MC, Dise, JH, Petersen, KT, Soane, D, Stokes, KK, Ware Jr, W & Thakrar, AC 2013, 'Systems and methods for removing finely dispersed particulate matter from a fluid stream', *US Patent 8,353,641*, Clean Teq Pty Ltd, Notting Hill.
- Fanni, R, Reid, D & Smith, K, 2019, 'On some considerations related to pore fluid chemistry in tailings critical state testing', *Proceedings of Tailings and Mine Waste 2019*, The University of British Columbia, Vancouver, pp. 983–1464.
- Fischmann, AJ, Spagnuolo, C, de Kretser, R, Sofrà, F & van der Linde, J 2025, 'Improving filtration efficiency with ATA® rapid dewatering technology', in AB Fourie, A Copeland, V Daigle & C MacRobert (eds), *Paste 2025: Proceedings of the 27<sup>th</sup> International Conference on Paste, Thickened and Filtered Tailings*, Australian Centre for Geomechanics, Perth, pp. 655–670, [https://doi.org/10.36487/ACG\\_repo/2555\\_47](https://doi.org/10.36487/ACG_repo/2555_47)
- Jefferies, MG & Been, K 2016, *Soil Liquefaction: Critical State Approach*, CRC press, Boca Raton.
- Ladd, R, 1978, 'Preparing test specimens using undercompaction', *Geotechnical Testing Journal*, vol. 1, no. 1, pp. 16–23.
- Mmbando, E, Fourie, A, Reid, D, Gao, J, Nasharuddin, R & Fridjonsson, E 2024a, 'Effects of structure and pore-water chemistry on critical state behavior of bauxite residue' *Canadian Geotechnical Journal*, vol. 62, pp. 1–17.
- Mmbando, E, Fourie, A, Reid, D & Gao, J 2024b, 'Effect of compressibility on the stress state of wet and dry bauxite residue', *Canadian Geotechnical Journal*, vol. 62, pp. 1–13.
- Reid, D, Fanni, R & DiDonna P 2022, 'The effect of tamping conditions on undrained shear strengths of a non-plastic sandy silt tailings', *Canadian Geotechnical Journal*, vol. 59, no. 6, pp. 783–795.
- Standards Australia 2008, *Methods of Testing Soils for Engineering Purposes, Method 3.4.1: Soil Classification Tests - Determination of the Linear Shrinkage of a Soil (AS 1289.3.4.1-2008)*, Sydney.
- Standards Australia 2009a, *Methods of Testing Soils for Engineering Purposes, Method 3.2.1: Soil Classification Tests - Determination of the Plastic Limit of a Soil - Standard Method (AS 1289.3.2.1-2009)*, Sydney.
- Standards Australia 2009b, *Methods of Testing Soils for Engineering Purposes, Method 3.3.1: Soil Classification Tests - Calculation of the Plasticity Index of a Soil (AS 1289.3.3.1-2009)*, Sydney.
- Standards Australia 2015, *Methods of Testing Soils for Engineering Purposes, Method 3.9.1: Soil Classification Tests - Determination of the Cone Liquid Limit of a Soil (AS 1289.3.9.1:2015)*, Sydney.
- Standards Australia 2017a, *Methods of Testing Soils for Engineering Purposes, Method 5.1.1: Soil Compaction and Density Tests - Determination of the Dry Density/moisture Content Relation of a Soil Using Standard Compactive Effort (1289.5.1.1:2017)*, Sydney.
- Standards Australia 2017b, *Methods of Testing Soils for Engineering Purposes, Method 5.2.1: Soil Compaction and Density Tests - Determination of the Dry Density/moisture Content Relation of a Soil Using Modified Compactive Effort (1289.5.2.1:2017)*, Sydney.
- Standards Australia 2025, *Methods of Testing Soils for Engineering Purposes, Part 3.5.1: Soil Classification Tests - Determination of the Soil Particle Density of a Soil - Standard Method (1289.3.5.1-2006 REC:2025)*, Sydney.
- Whatnall, O, Barber, K & Robinson, P 2021, 'Tailings filtration using viper filtration technology—a case study', *Mining, Metallurgy & Exploration*, vol. 38, pp. 1297–1303.